

INSTRUCTION MANUAL
for
ALT-930-2M
TRIPLE LOOP ANTENNA
and
ALT-930-CKIT
CALIBRATION KIT

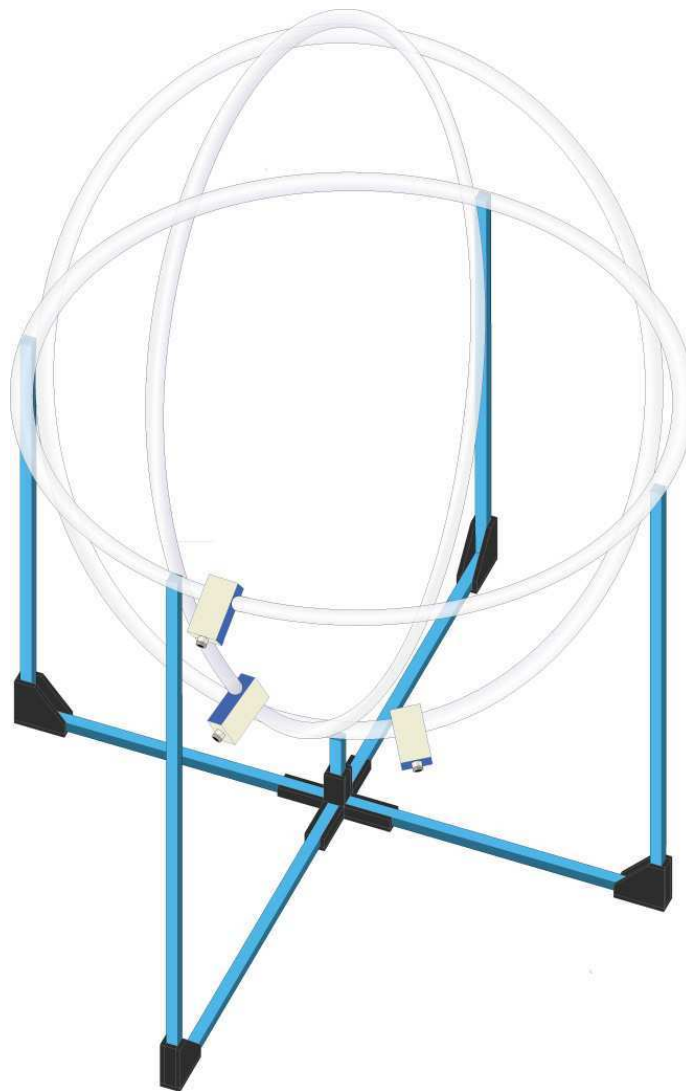

Table of Contents

1.0	Introduction	5
2.0	Products Available from Com-Power	6
3.0	Product Information	7
3.1	Incoming Inspection.....	7
3.2	Package Inventory	7
3.3	ALT-930-2M Components/Subassemblies	8
3.4	ALT-930-CKIT Components/Subassemblies (optional)	9
3.5	ALT-930-2M Specifications.....	10
3.6	ALT-930-CKIT Calibration Kit (Balun-Dipole) Specifications	10
4.0	Assembly Instructions - ALT-930-2M Triple Loop Antenna	13
5.0	Assembly Instructions - ALT-930-CKIT Calibration Kit	21
5.1	Changing the Polarity of the Balun-Dipole.....	22
6.0	Using the ALT-930-2M Triple Loop Antenna	23
6.1	Theory of Operation	23
6.1.1	Antenna Correction Factors.....	24
6.2	Operation of CS-450 Coaxial Switch	26
6.2.1	Local Operation of CS-450 Coaxial Switch	26
6.2.2	Remote Operation of CS-450 Coaxial Switch using RLI-100 Remote Interface	27
6.3	Radiated Electromagnetic Disturbance Measurements	28
6.3.1	Interpolation of Antenna Correction factors.....	30
7.0	Calibration	31
7.1	Calibration Equipment.....	31
7.1.1	Source Equipment.....	31
7.1.2	Measuring Instruments.....	31
7.1.3	Balun-Dipole as Transmitting Antenna.....	31
7.2	Calibration Parameters.....	32
7.2.1	Required Measurements.....	32
7.2.2	Calibration Frequencies.....	33
7.2.3	Amplitude of the Signal Source Output	34
7.3	Calibration Process.....	35
7.3.1	Reference Measurements	36
7.3.2	Calibration Measurements	37
8.0	Warranty.....	43
9.0	Maintenance	44

- TABLE OF CONTENTS -

List of Figures

Figure 1 - Components/Subassemblies of the ALT-930-2M Assembly	8
Figure 2 – Components/Subassemblies of the ALT-930-CKIT Calibration Kit	9
Figure 3 - Dimensions of ALT-930-2M Assembly	11
Figure 4 - Dimensions of ALT-930-CKIT Assembly	12
Figure 5 - ALT-930-2M Triple Loop Antenna Assembly – Step #1	13
Figure 6 - ALT-930-2M Triple Loop Antenna Assembly – Step #2	13
Figure 7 - ALT-930-2M Triple Loop Antenna Assembly – Step #3	14
Figure 8 - ALT-930-2M Triple Loop Antenna Assembly – Step #4	14
Figure 9 - ALT-930-2M Triple Loop Antenna Assembly – Step #5	15
Figure 10 - ALT-930-2M Triple Loop Antenna Assembly – Step #6	15
Figure 11 - ALT-930-2M Triple Loop Antenna Assembly – Step #7	16
Figure 12 – ALT-930-2M Triple Loop Antenna Assembly – Step #8	17
Figure 13 – ALT-930-2M Triple Loop Antenna Assembly – Step #9	17
Figure 14 – ALT-930-2M Triple Loop Antenna Assembly – Step #10	18
Figure 15 - ALT-930-2M Triple Loop Antenna Assembly – Step #11	19
Figure 16 - ALT-930-2M Triple Loop Antenna Assembly – Step #12	20
Figure 17 - ALT-930-CKIT Calibration Kit Assembly – Step #1	21
Figure 18 - ALT-930-CKIT Calibration Kit Assembly – Step #2	21
Figure 19 - ALT-930-CKIT Calibration Kit Assembly – Step #3	22
Figure 20 - Changing the Polarity of the Balun-Dipole Antenna	22
Figure 21 - Typical Antenna Correction Factors Graph	25
Figure 22 - Typical Setup for Local Operation using CS-450 Coaxial Switch	26
Figure 23 - Setup for Remote Operation of CS-450 Switch via RLI-100 Remote Interface	27
Figure 24 - Typical Test Setup for Disturbance Measurements	28
Figure 25 – CISPR 15/EN 55015 Radiated Disturbance Limits for 2-meter Loop	29
Figure 26 - Balun-Dipole Positions During Calibration	32
Figure 27 - 'Keyed' Mounting of Balun-Dipole onto Mounting Block	32
Figure 28 - Equipment Setup for Reference Level Measurements	36
Figure 29 - Measurement Arrangement for X-axis Calibration	37
Figure 30 - Measurement Arrangement for Y/Z-axis Calibration	38
Figure 31 - Validation Factor Graph from CISPR 16-1-4	42

- LISTS OF FIGURES, TABLES & EQUATIONS -

List of Tables

Table 1 - ALT-930-2M Specifications	10
Table 2 - ALT-930-CKIT (Balun-Dipole) Specifications.....	10
Table 3 - Cable Connections Table	20
Table 4 - Typical Antenna Correction factors Table.....	25
Table 5 – Cross-reference Table of RLI-100 Buttons vs CS-450 Input Channels.....	27
Table 6 - Required Calibration Measurements Table	33
Table 7 - Recommended Calibration Frequencies	33
Table 8 - Example Calibration Results Table #1	39
Table 9 - Example Calibration Results Table #2.....	40
Table 10 - Example Calibration Results Table #3.....	40
Table 11 - Example Calibration Results Table #4.....	41

List of Equations

Equation 1 – Measured Voltage/Radiated Disturbance Level (Loop Current) Relationship.....	24
Equation 2 – Interpolation of Factors	30
Equation 3 – Conversion of Linear Voltage to Logarithmic.....	36
Equation 4 – Calculating the average of X1...X8, Y1...Y8 & Z1...Z8.....	39
Equation 5 – Correction of XA/YA/ZA Values	40
Equation 6 – Calculating the Average of XC, YC & ZC	41
Equation 7 – Calculation of ΔXYZ	41
Equation 8 – Calculation of Antenna Correction factor	42

1.0 Introduction

This manual includes descriptions of product features; product specifications, safety precautions, operational instructions, antenna theory, measurement guidelines, warranty and product maintenance information.

Information contained in this manual is the property of Com-Power Corporation. It is issued with the understanding that the material may not be reproduced or copied without the express written permission of Com-Power.

2.0 Products Available from Com-Power



Antennas



Antenna Kits



Absorbing Clamps



Coupling/Decoupling Networks (CDNs)



Comb Generators



Current Probes & Injection Probes



Emissions Test Systems



Conducted Immunity Test Systems



Impedance Stabilization Networks (ISNs)



Line Impedance Stabilization Networks (LISNs)



Antenna Masts



Near-Field Probe Sets



Preamplifiers



Power Amplifiers



Spectrum Analyzers



Surge Generators



Transient Limiters



Turntables



Antenna Tripods



Telecom Test Systems

www.com-power.com

SECTION 2 - PRODUCTS AVAILABLE FROM COM-POWER

19121 EL TORO ROAD • SILVERADO, CALIFORNIA 92676 • (949) 459-9600 • com-power.com

Rev072318

3.0 Product Information

3.1 Incoming Inspection

Please check the contents of the shipment against the package inventory in section 3.2 to ensure that you have received all applicable items.

3.2 Package Inventory

STANDARD ITEMS:

- **ALT-930-2M Triple Loop Antenna**
 - ✓ (3) 2-meter diameter insulated loops with male N-connectors
 - ✓ (3) Current to voltage transducers
 - ✓ (1) **CS-450** Four-Channel Coaxial Switch
 - ✓ (3) 2-meter coaxial cable assemblies with molded ferrites and male BNC connectors for connection between current to voltage transducers and Four-Channel Coaxial Switch.
 - ✓ (1) 8-meter coaxial cable assembly with male BNC connectors for connection between the coaxial switch and measuring instrument
 - ✓ Triple Loop Mounting Structure
 - (1) Central support hub with swivel caster
 - (4) Corner base supports with swivel caster, vertical Post & dual loop clamp
 - (1) 0.5-meter vertical center post with dual loop clamp
 - (4) 1-meter horizontal support beams
 - (1) Top dual loop clamp

OPTIONAL ITEMS:

- **ALT-930-CKIT Calibration Kit**
 - ✓ Balun-Dipole transmit antenna for calibration
 - ✓ Balun-Dipole mounting structure
 - (1) Horizontal support piece with (4) leg clamps and mounting block post clamp
 - (4) Mounting structure legs
 - (4) Leg stabilizing cross-bars
 - (1) Mounting block post
 - (1) Balun-Dipole mounting block
 - ✓ 10-meter coaxial cable with BNC type (male) connectors
- **RLI-100 Remote Switch w/Fiber Optic Interface**
 - ✓ 10-meter Fiber Optic Cable (Duplex Latching POF Connector at each end)
 - ✓ (2) AC Power Adapters (6 Volts DC, 500 mA, unregulated)

SECTION 3 - PRODUCT INFORMATION

3.3 ALT-930-2M Components/Subassemblies

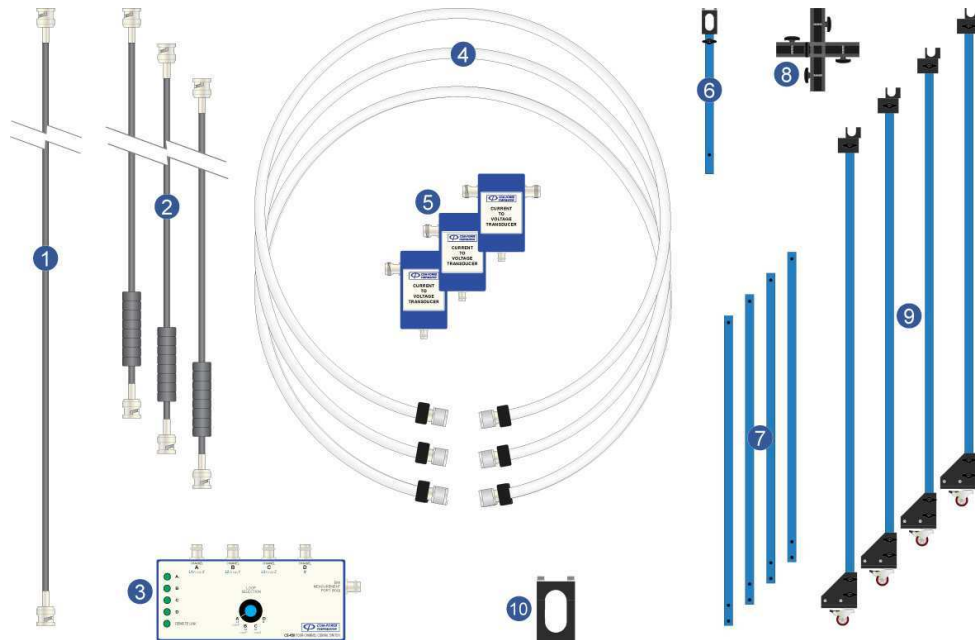

Figure 1 - Components/Subassemblies of the ALT-930-2M Assembly

- 1 (1) 8-meter Coaxial Cable**
Coaxial RG 223/U cable with male BNC connectors for connection between coaxial switch **3** and measuring instrument.
- 2 (2) 2-meter Coaxial Cables**
Coaxial RG 223/U cables with molded ferrites at one end; fitted with male BNC connectors for connection between the Current to Voltage Transducers **5** and the CS-450 Four-Channel Coaxial Switch **3**.
- 3 (1) CS-450 Four-Channel Coaxial Switch**
Coaxial switch used to select which loop is connected to the measuring instrument, while terminating the other two loops into fifty ohms.
- 4 (3) 2-meter diameter Insulated Loops**
Loops constructed as defined in CISPR 16-1-4. Each loop is fitted with a male N-type connector at each end for connection to either side of a Current to Voltage Transducer **5**.
- 5 (3) Current to Voltage Transducers**
Convert the loop currents into a voltage quantity to be measured.
- 6 (1) 0.5-meter Vertical Center Post with Dual Loop Clamp**
Mounts into the center hole on the Central Support Hub **8**, providing support for vertical loops.
- 7 (4) Horizontal Support Beams**
One end of each fiber glass beam installs into the four horizontal channels of the Central Support Hub **8**. The opposite end of each installs into the horizontal channel of the Corner Base Supports **9**.
- 8 (1) Central Support Hub with Swivel Caster**
Provides support for vertically mounted loop assemblies, and provides center support for the antenna assembly along with mounting provisions for the (4) Horizontal Support Beams **7**.
- 9 (4) Corner Base Supports w/Swivel Caster, Vertical Post & Dual Loop Clamp**
Provide mounting provisions for the (4) Horizontal Support Beams **7**, and support for each corner of the triple loop assembly.
- 10 (1) Top Dual Loop Clamp**
Clamps the tops of the Y-axis and Z-axis loops together.

SECTION 3 - PRODUCT INFORMATION

3.4 ALT-930-CKIT Components/Subassemblies (optional)

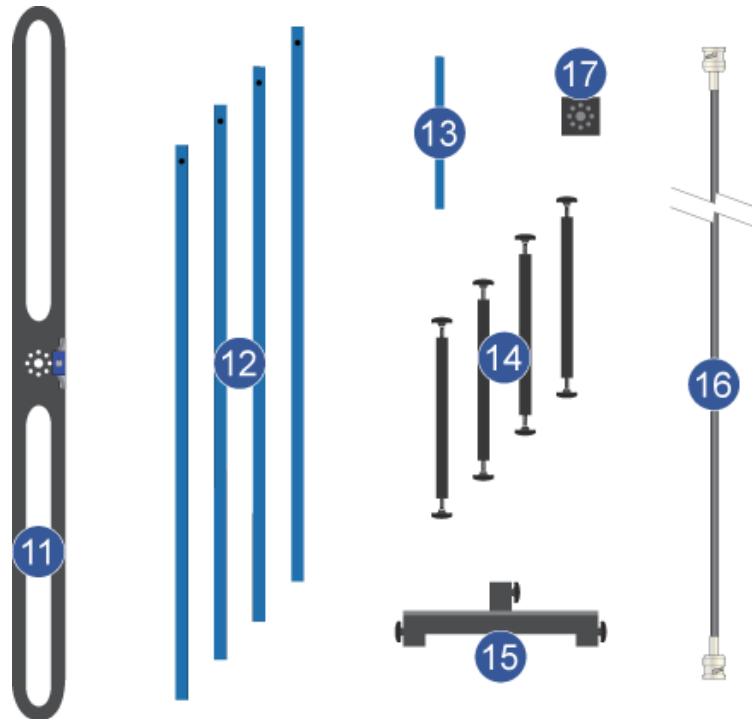

Figure 2 – Components/Subassemblies of the ALT-930-CKIT Calibration Kit

- 11 (1) Balun-Dipole Calibration Antenna**
Balun-Dipole antenna constructed as described in CISPR 16-1-4, fitted with a female BNC-type output connector.
- 12 (4) Mounting Structure Legs**
Fiber glass posts which attach to the (4) leg clamps on the under side of the Horizontal Support Piece¹⁵.
- 13 (1) Mounting Block Post**
Fiber glass post which attaches to the mounting block post clamp on the top side of the Horizontal Support Piece¹⁵. The Balun-Dipole Mounting Block¹⁷ slides onto the top of this post.
- 14 (4) Leg Stabilizing Cross-bars**
Black colored bars which attach between the Mounting Structure Legs¹² for stability.
- 15 Horizontal Support Piece with (4) Leg Clamps and (1) Clamp for Vertical Post**
The tops of the four (4) Mounting Structure Legs¹² are secured by the four leg clamps on the under side of this piece, while the Mounting Block Post¹³ is secured by the mounting block post clamp on its top side. This piece can also serve as the table-top on which small devices can be placed during testing by removing the mounting block post clamp (see section 6.2).
- 16 (1) 10-meter Coaxial Cable**
Coaxial RG 223/U cable with male BNC connectors for connection between Balun-Dipole antenna and signal source.
- 17 (1) Balun-Dipole Mounting Block**
Provides the mounting mechanism for the balun-dipole. This block slides onto the Vertical Post¹³.

SECTION 3 - PRODUCT INFORMATION

3.5 ALT-930-2M Specifications

Table 1 - ALT-930-2M Specifications

Frequency Range	9 kHz to 30 MHz
Standard(s)	CISPR 16-1-4, CISPR 15
Loops	(3) independent, insulated loops, switchable
Diameter of Loops	2 meters
Loop Construction	RG 223/U Coaxial Cable in 1" PEX pipe
Output Port Impedance	50 ohms
Output Connector	Coaxial BNC (female)
Mounting Structure Construction	Fiber Glass/Plastic
Weight	65.5 lbs. (29.7 kg)
Overall Dimensions (H)x(W)x(D)	2.54 x 2.1 x 2.1 meters
Operating Temperature	0° C to 40° C

All values are typical, unless specified.
All specifications are subject to change without notice.

3.6 ALT-930-CKIT Calibration Kit (Balun-Dipole) Specifications

Table 2 - ALT-930-CKIT (Balun-Dipole) Specifications

Frequency Range	9 kHz to 30 MHz
Standard(s)	CISPR 16-1-4
Balun-Dipole Loop Dimensions	1.5 x 0.1 x 0.006 meters
Balun-Dipole Construction	RG 223/U Coaxial Cable
Input Port Impedance	50 ohms
Input Connector	Coaxial BNC (female)
Mounting Structure Construction	Fiber Glass/Plastic
Weight	25 lbs. (11.34 kg)
Overall Dimensions (H)x(W)x(D)	1.56 x 1.5 x 0.5 meters
Operating Temperature	0° C to 40° C

All values are typical, unless specified.
All specifications are subject to change without notice.

SECTION 3 - PRODUCT INFORMATION

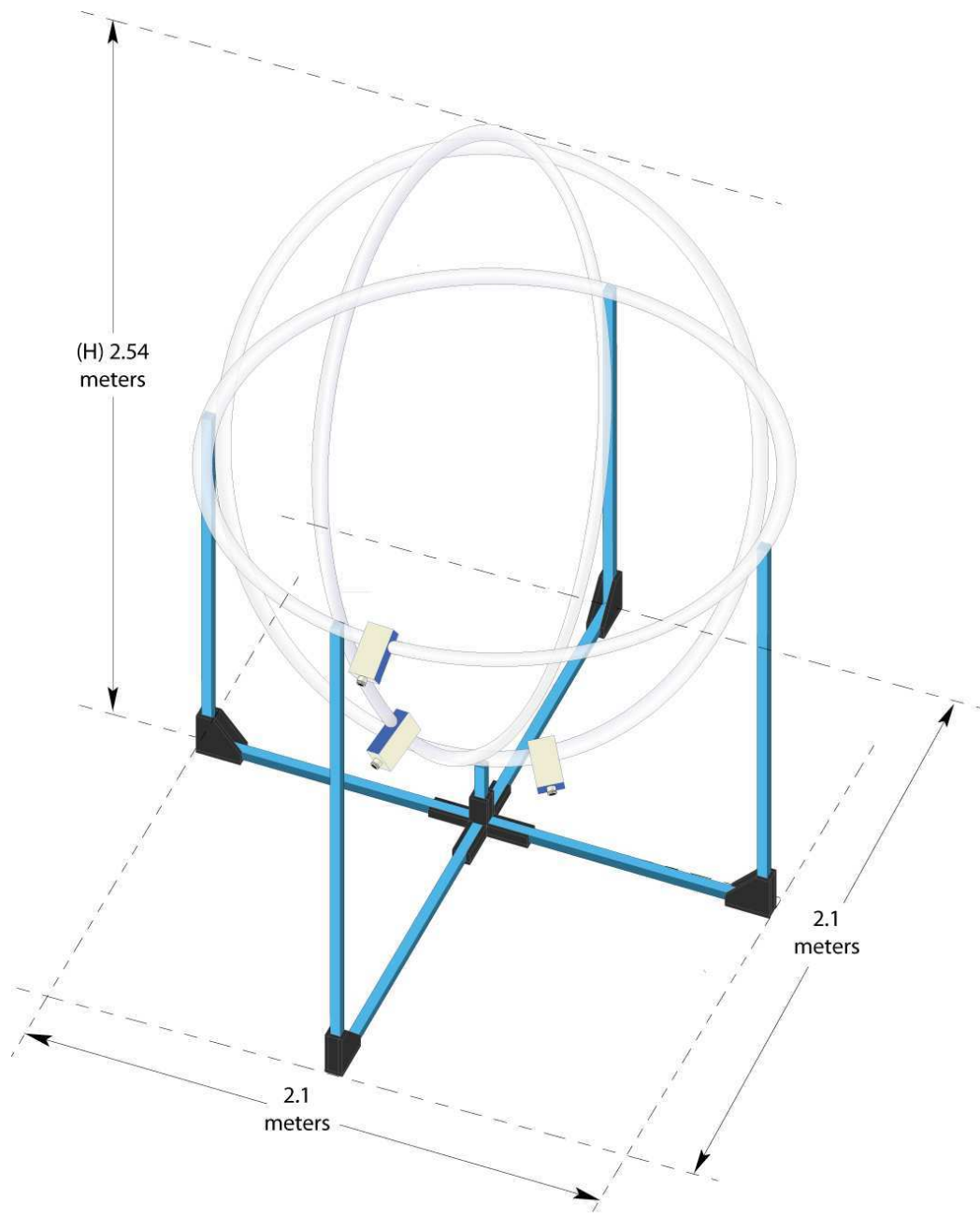

Figure 3 - Dimensions of ALT-930-2M Assembly

SECTION 3 - PRODUCT INFORMATION

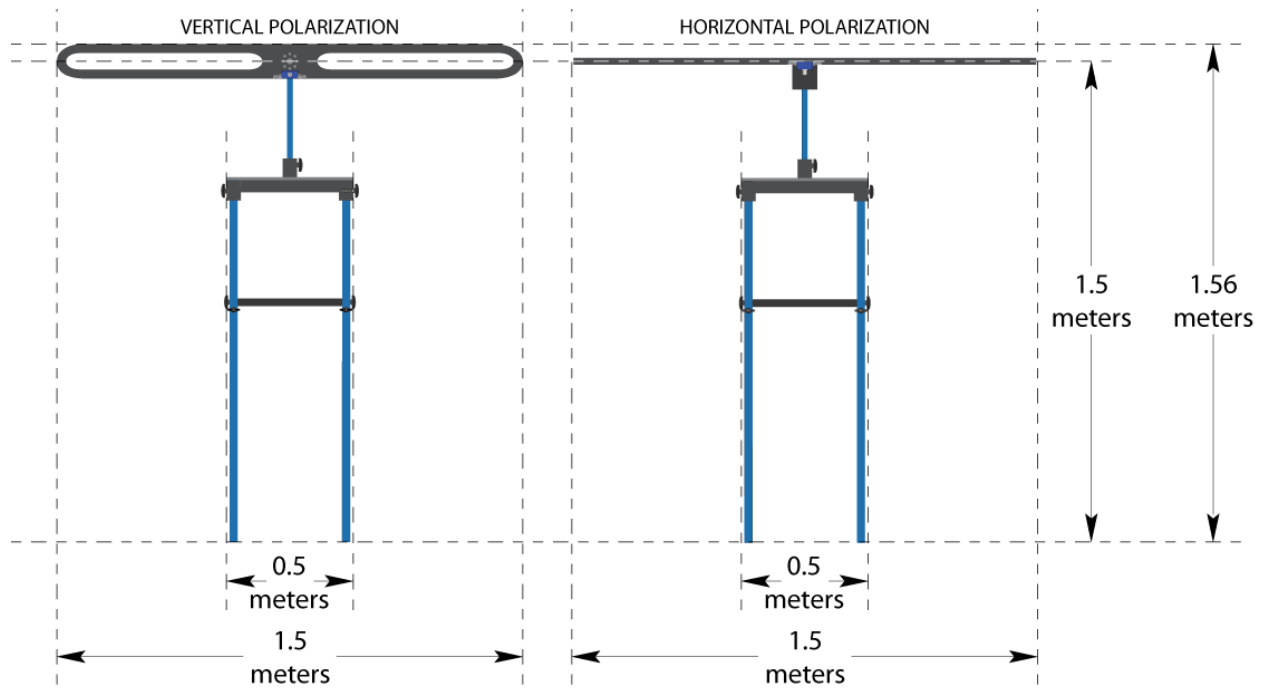

Figure 4 - Dimensions of ALT-930-CKIT Assembly

SECTION 3 - PRODUCT INFORMATION

4.0 Assembly Instructions - ALT-930-2M Triple Loop Antenna

Step #1 Unscrew and remove the five (5) finger-knob bolts from the Central Support Hub⁸ as shown in Figure 5.

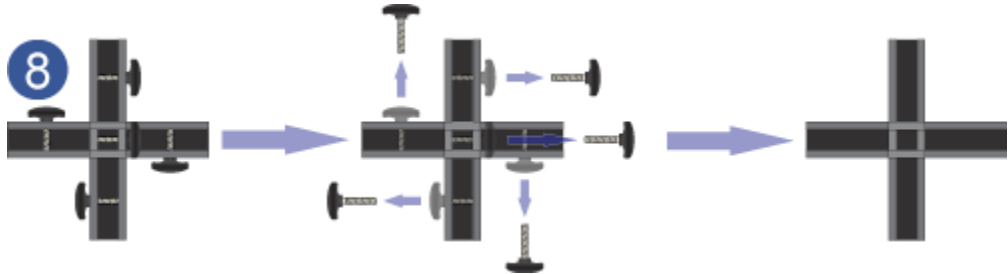

Figure 5 - ALT-930-2M Triple Loop Antenna Assembly – Step #1

Step #2 Insert the ends of the Horizontal Support Beams⁷ which have only one hole into the four channels of the Central Support Hub⁸ so that the hole through each beam aligns with respective holes in the walls of the channels. Then re-insert the four finger-knob bolts and tighten to firmly lock the support beams in place. Refer to Figure 6.



Figure 6 - ALT-930-2M Triple Loop Antenna Assembly – Step #2

Step #3 Insert the 0.5-meter Vertical Center Post with Dual Loop Clamp⁶ into the center hole of the Central Support Hub⁸ as shown in Figure 7 until it reaches the bottom of the hole. Re-insert the last finger-knob bolt through the center post and tighten to secure the center post firmly in place.

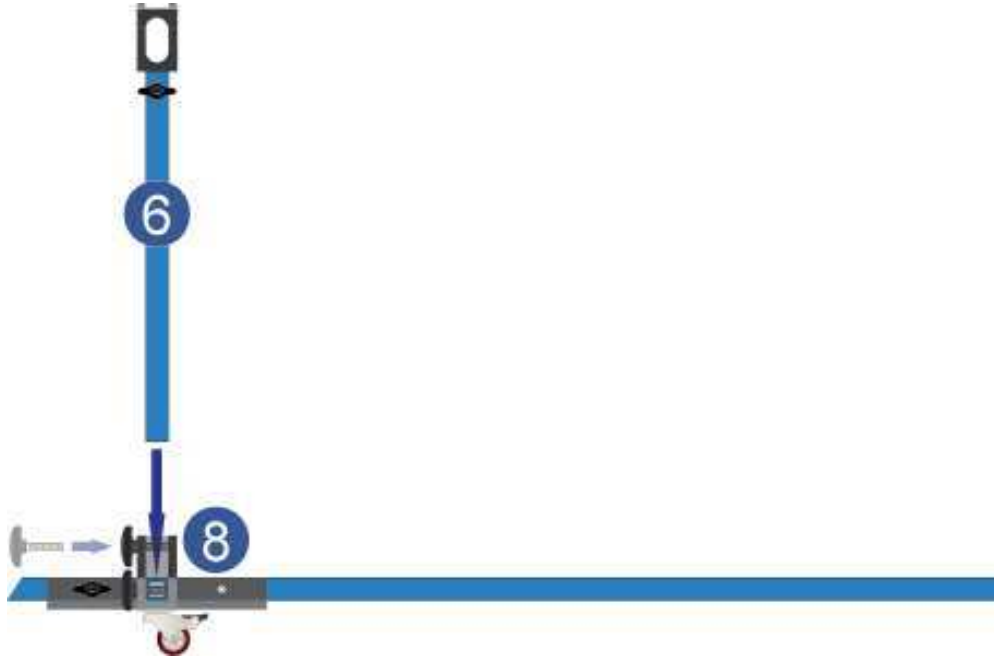

Figure 7 - ALT-930-2M Triple Loop Antenna Assembly – Step #3

Step #4 Remove the two bottom finger-knob bolts from each of the four Corner Base Supports with Swivel Casters, Vertical Post & Dual Loop Clamp Assembly⁹ as shown in Figure 8.

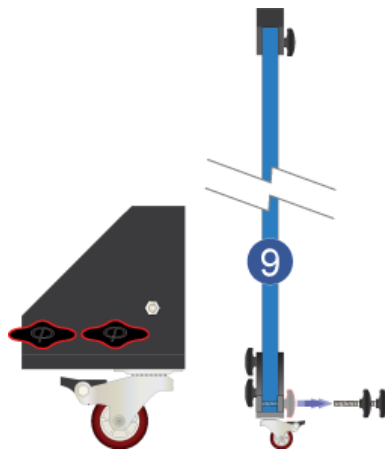

Figure 8 - ALT-930-2M Triple Loop Antenna Assembly – Step #4

SECTION 4 - ASSEMBLY INSTRUCTIONS FOR ALT-930-2M TRIPLE LOOP ANTENNA

Step #5 Insert the unattached ends of the Horizontal Support Beams⁷ into the horizontal channel of each of the Corner Base Supports with Swivel Caster, Vertical Post & Dual Loop Clamp Assemblies⁹ as shown in Figure 9. Re-insert all eight (8) finger-knob bolts through the support beams and tighten to lock the beams firmly in place. This completes the assembly of the antenna mounting structure.

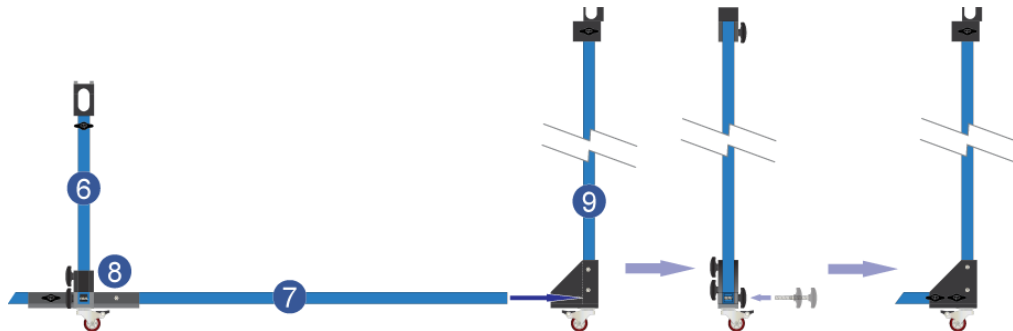

Figure 9 - ALT-930-2M Triple Loop Antenna Assembly – Step #5

Step #6 With each of the three (3) 2-meter diameter Insulated Loops^{4a/4b/4c}, screw and tighten each of the male N-connectors onto the mating female N-connectors on either side of each of the three (3) respective Current to Voltage Transducers^{5a/5b/5c} as shown in Figure 10.

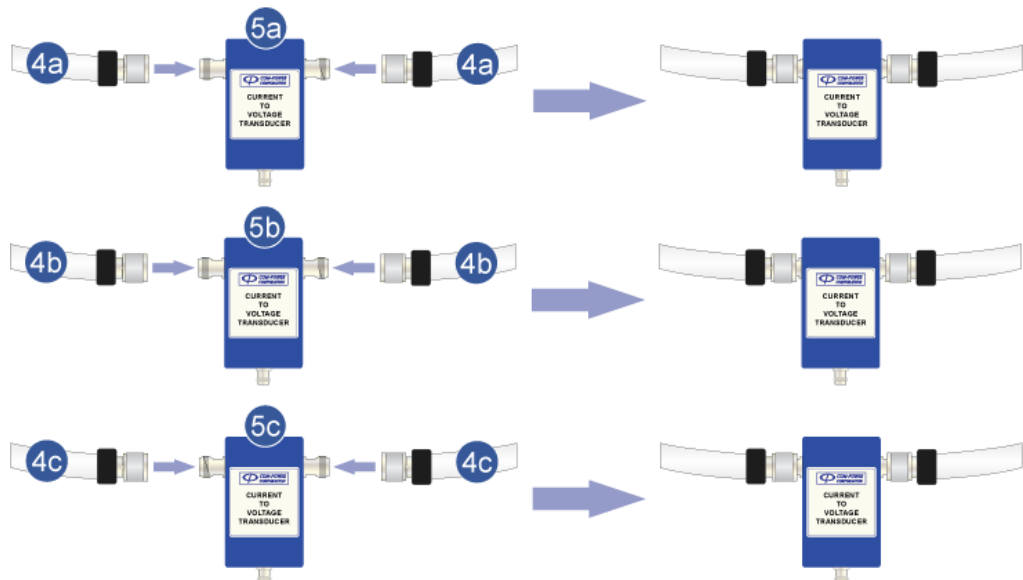

Figure 10 - ALT-930-2M Triple Loop Antenna Assembly – Step #6

SECTION 4 - ASSEMBLY INSTRUCTIONS FOR ALT-930-2M TRIPLE LOOP ANTENNA

Step #7 Place one of the loop assemblies^{4a/5a} onto the antenna mounting structure in the X-axis (parallel with the floor) as shown in Figure 11. The loop assembly should be rotated such that the Current to Voltage Transducer^{5a} is located near one of the vertical supports in order to avoid excessive 'drooping' of the loop.

OVERHEAD VIEW

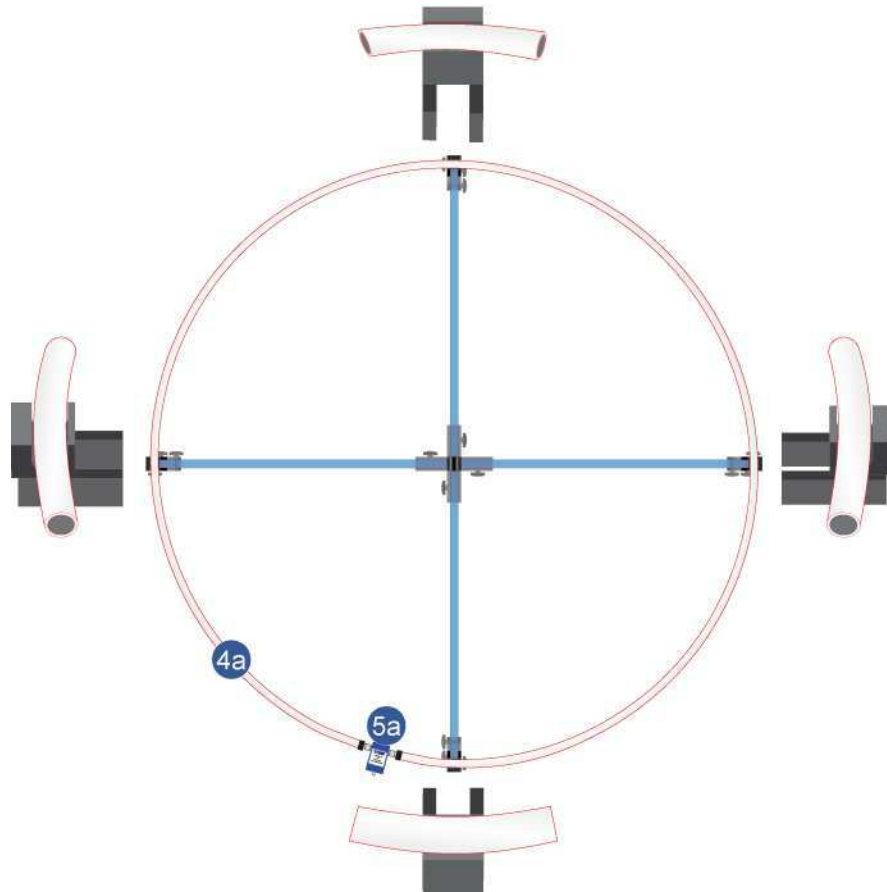

Figure 11 - ALT-930-2M Triple Loop Antenna Assembly – Step #7

Step #8 As shown in Figure 12, unscrew the four small bolts from the top of the dual loop clamp mounted on top of the center post⁶. Remove the top of the clamp so that the loop can be placed inside.

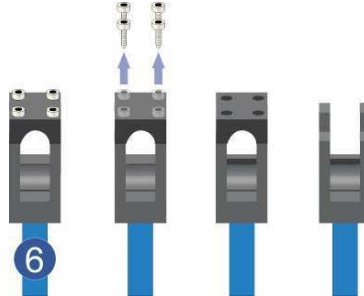

Figure 12 – ALT-930-2M Triple Loop Antenna Assembly – Step #8

Step #9 Install the second loop^{4b}/^{5b} inside of the X-axis loop^{4a} as shown in Figure 13. The loop assembly should be rotated such that the Current to Voltage Transducer^{5b} is located near the Vertical Center Post and in the same quadrant as the X-axis transducer^{5a}.

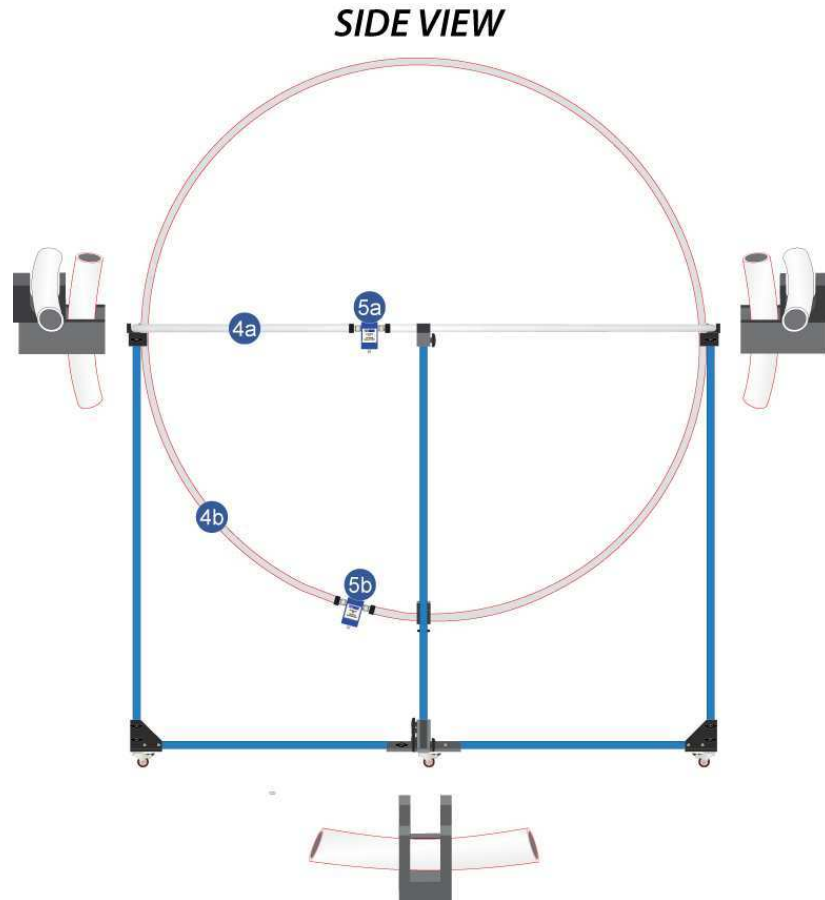

Figure 13 – ALT-930-2M Triple Loop Antenna Assembly – Step #9

SECTION 4 - ASSEMBLY INSTRUCTIONS FOR ALT-930-2M TRIPLE LOOP ANTENNA

Step #10 Install the final loop assembly^{4c/5c} perpendicular to the other vertically oriented loop assembly^{4b/5b}. As shown in Figure 14, the bottom of the loop^{4c} is mounted inside (on top of) the bottom of the perpendicular loop^{4b}, while the top of the loop is outside (also on top of) the top of the perpendicular loop. In order to accomplish this, one of the loop's N-connectors will have to be temporarily disconnected from its respective Current to Voltage Transducer^{5c} in order to interweave the two loops. Once it is reconnected, the loop assembly should be rotated such that the Current to Voltage Transducer^{5c} is located near the Vertical Center Post and in the same quadrant as the other two transducers^{5a/5c}. Replace the top of the dual loop clamp attached to the center post using the four small bolts removed in Step #8.

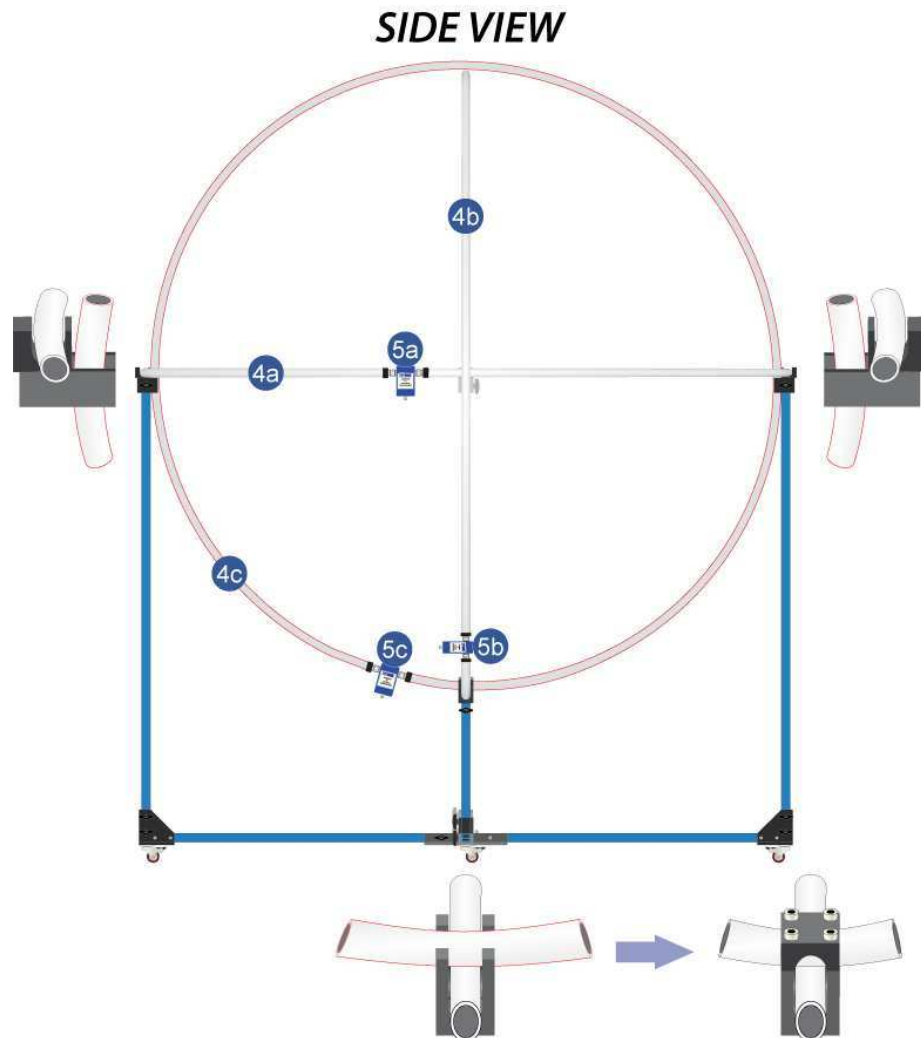

Figure 14 – ALT-930-2M Triple Loop Antenna Assembly – Step #10

SECTION 4 - ASSEMBLY INSTRUCTIONS FOR ALT-930-2M TRIPLE LOOP ANTENNA

Step #11 Remove the four small bolts from the top dual loop clamp¹⁰ to separate the clamp into two pieces. Slide the larger piece down over the top of the Y-axis and Z-axis loops where they intersect at the center of the loop assembly as shown in Figure 15. Re-join the two clamp pieces by replacing and tightening the four small bolts.

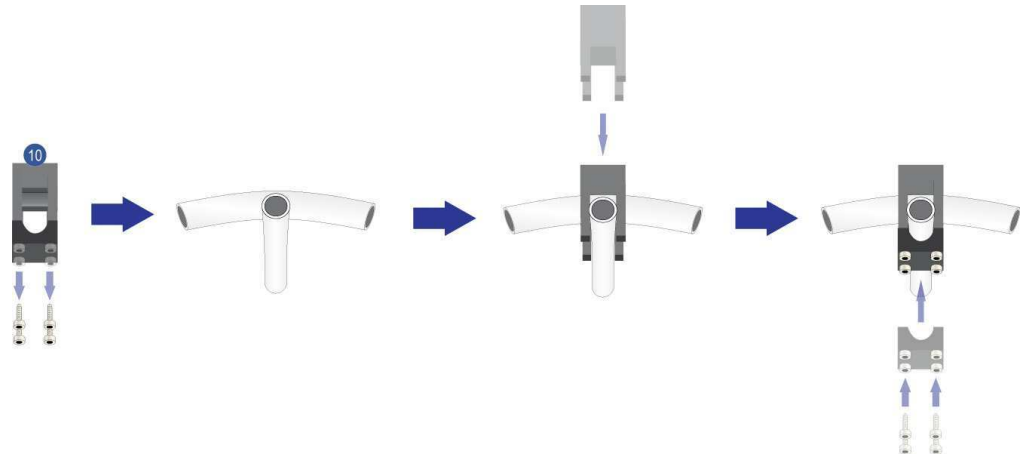

Figure 15 - ALT-930-2M Triple Loop Antenna Assembly – Step #11

Step #12 The last step of the assembly is to connect the measurement cables. The three cables with molded ferrites at one end (2a/2b/2c) are used to connect the Current to Voltage Transducers (5a/5b/5c) to the respective inputs of the Four-Channel Coaxial Switch (3) as shown in Figure 16. The remaining cable (1) is used to connect the switch output to the measuring instrument. The exact connections are given in Table 3, and shown in Figure 16.

Table 3 - Cable Connections Table

CABLE	COMPONENT/PORT	COMPONENT/PORT
1	Measurement Port Output of 4-Channel Coaxial Switch (3)	50Ω RF Input of Measuring Instrument
2a	X-axis Current to Voltage Transducer (5a)	Channel A (Loop X) Input of 4-Channel Coaxial Switch (3)
2b	Y-axis Current to Voltage Transducer (5b)	Channel B (Loop Y) Input of 4-Channel Coaxial Switch (3)
2c	Z-axis Current to Voltage Transducer (5c)	Channel C (Loop Z) Input of 4-Channel Coaxial Switch (3)

NOTE: Cables (2a/2b/2c) must be connected with the ferrites nearest the Four-Position Switch.

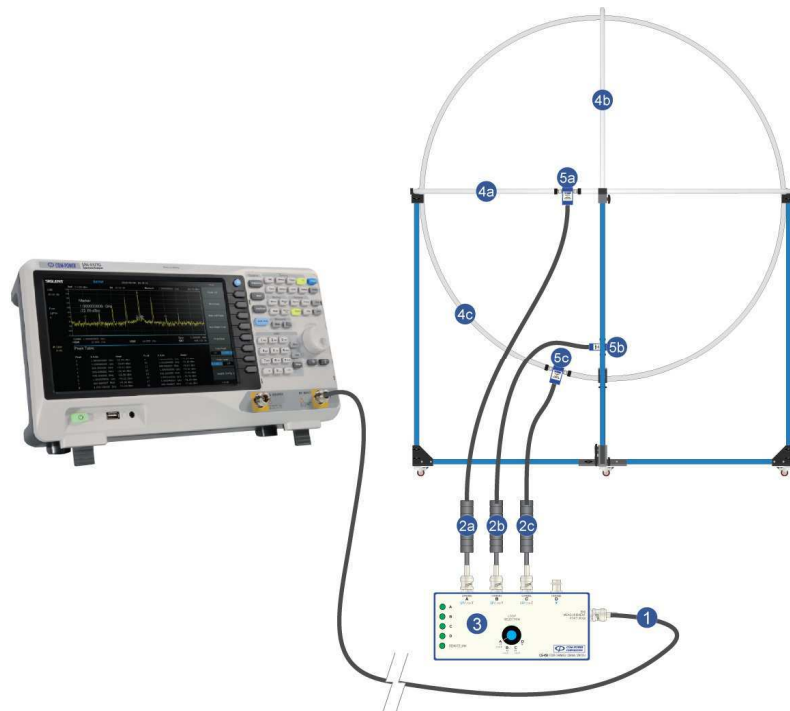

Figure 16 - ALT-930-2M Triple Loop Antenna Assembly – Step #12

SECTION 4 - ASSEMBLY INSTRUCTIONS FOR ALT-930-2M TRIPLE LOOP ANTENNA

5.0 Assembly Instructions - ALT-930-CKIT Calibration Kit

Step #1

As shown in Figure 17, unscrew and remove the five (5) finger-knob bolts from the leg/post clamps attached to the top and bottom of the Horizontal Support Piece¹⁵. Insert the (4) Mounting Structure Legs¹² into the leg clamps on the under side of the Horizontal Support Piece¹⁵. Insert the Mounting Block Post¹³ into the antenna mounting post clamp on the top side of the Horizontal Support Piece¹⁵. Re-insert the five (5) finger-knob bolts and tighten. Slide the Balun-Dipole Mounting Block¹⁷ onto the Mounting Block Post¹³ for the desired orientation/polarity of the Balun-Dipole (see section 5.1).

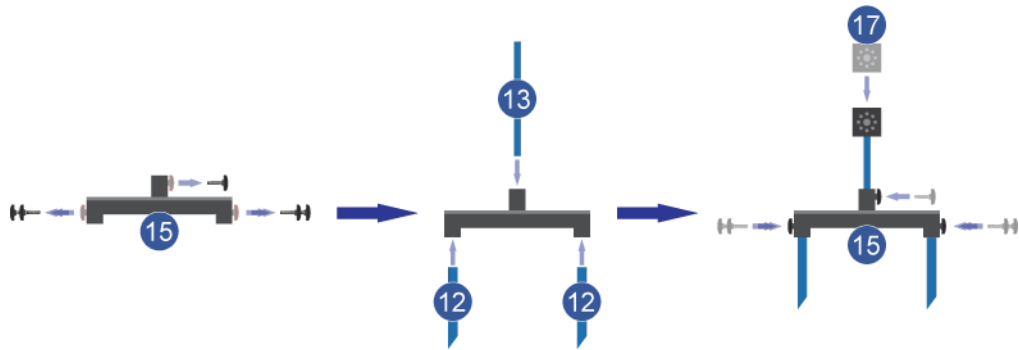

Figure 17 - ALT-930-CKIT Calibration Kit Assembly - Step #1

Step #2

As shown in Figure 18, unscrew and remove the two (2) finger-knob bolts from each of the four (4) leg-stabilizing cross-bars¹⁴, for a total of eight (8) bolts removed. One cross-bar at a time, line cross-bar¹⁴ up between the pre-drilled holes in two adjacent Mounting Structure Legs¹². Once aligned, insert the finger-knob bolts through the legs into either side of the cross-bar and tighten.

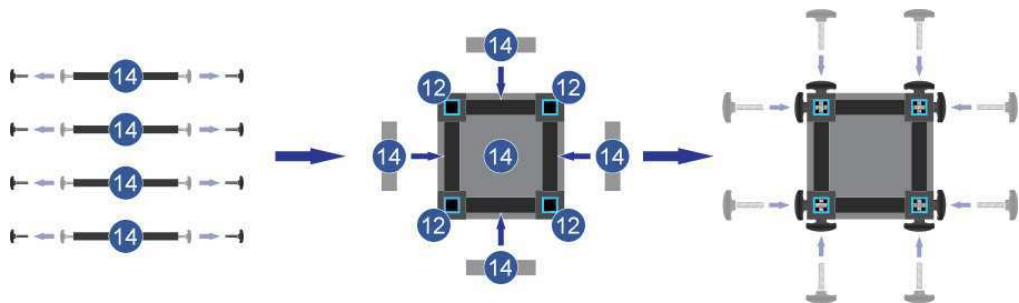

Figure 18 - ALT-930-CKIT Calibration Kit Assembly - Step #2

Step #3 As shown in Figure 19, unscrew and remove the nut from the Balun-dipole Mounting Block. Fit the Balun-dipole¹¹ onto the mounting block in the desired position, so that the nine cylinder-shaped protrusions on the mounting block slide into the matching holes in the center of the balun-dipole (see section 7.2). Replace the nut and tighten over the balun-dipole so that it is securely locked in place.

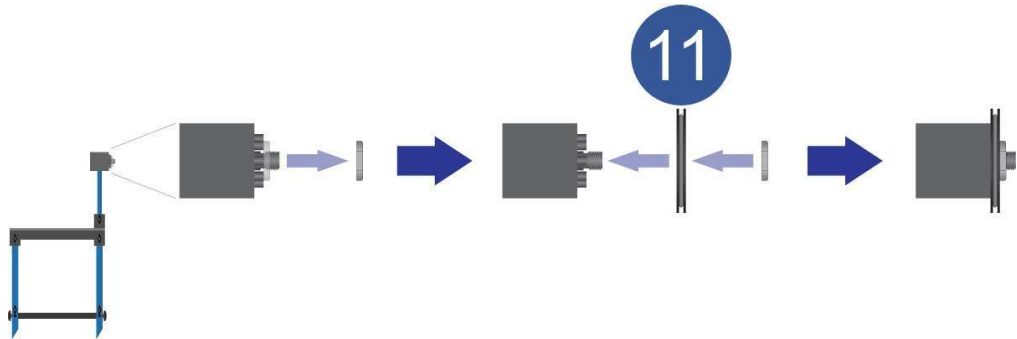

Figure 19 - ALT-930-CKIT Calibration Kit Assembly – Step #3

5.1 Changing the Polarity of the Balun-Dipole

There are two holes on the Balun-dipole Mounting Block into which the Mounting Block Post can be inserted. To change the polarity of the Balun-dipole, slide the Balun-dipole Mounting Block off of the Mounting Block Post; rotate 90 degrees and slide it back onto the post into the opposite hole. Refer to Figure 20.

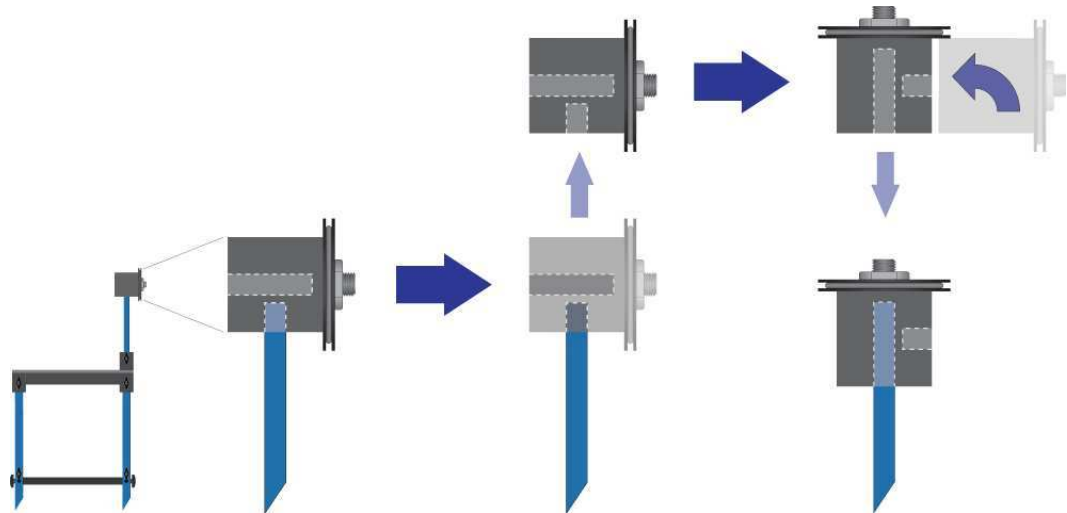

Figure 20 - Changing the Polarity of the Balun-Dipole Antenna

6.0 Using the ALT-930-2M Triple Loop Antenna

6.1 Theory of Operation

The ALT-930-2M Triple Loop Antenna is designed based on the Loop Antenna System (LAS) described in Annex C of CISPR 16-1-4. The antenna consists of three mutually perpendicular large loop antennas, each connected in series with a current to voltage transducer. The outputs of the transducers connect to three respective inputs on a coaxial switch. The output of the switch connects to the measuring instrument.

The magnetic fields generated by the EUT induce currents onto the loops. The current to voltage transducers convert these loop currents into corresponding voltage quantities to either be measured by a measuring instrument having an input impedance of 50 ohms, or be terminated directly into 50 ohms, depending on the position of the coaxial switch.

The measured voltage quantity is then converted back to a current quantity by applying the antenna correction factor, which is discussed in detail in Section 6.1.1.

The primary application for this antenna is the measurement of radiated magnetic fields (or radiated electromagnetic disturbances) generated by various types of electrical lighting and similar equipment while located in the approximate center of the Triple Loop Antenna structure.

6.1.1 Antenna Correction Factors

The Loop Antenna System (LAS) described in the CISPR 16-1-4 standard suggests that the current to voltage transducers (current probes) for each loop antenna have a sensitivity of one (1) volt per ampere over the frequency range of 9 kHz to 30 MHz. Furthermore, if the calibration of the antenna yields results within ± 2 dB of the theoretical validation factor given in Figure C.3 of the CISPR 16-1-4 standard over the frequency range of the antenna, then the effective antenna factor is zero.

An alternative approach to that described above is implemented for the ALT-930-2M Triple Loop Antenna, in that the response of the current to voltage transducers (current probes) vary with respect to frequency.

In order to account for this difference, the ALT-930-2M is provided with frequency-dependent antenna correction factors, such as those supplied with most other EMC-related antennas (active and non-active), impedance stabilizing networks, absorbing clamps, etc.

The antenna correction factors are determined through calibration measurements performed according to the CISPR 16-1-4 prescribed procedures, with the exception that at any given frequency, the difference between the theoretical validation factor given in the standard and the calibration results is considered to be the antenna correction factor.

This antenna correction factor, when applied, converts the measured voltage quantity (in $\text{dB}\mu\text{V}$) back to a current quantity (in $\text{dB}\mu\text{A}$) corresponding to the current flowing through the loop, which is considered to be the radiated disturbance level. The radiated disturbance level is then compared against the applicable radiated disturbance limit. The relationship between the measured voltage and the radiated disturbance level is defined in Equation 1.

Equation 1 – Measured Voltage/Radiated Disturbance Level (Loop Current) Relationship

$$\begin{array}{rcccl}
 \text{Radiated Disturbance} & & \text{Measured} & & \text{Antenna} \\
 \text{Level (loop current)} & = & \text{Voltage} & + & \text{Correction Factor} \\
 \text{(in dB}\mu\text{A)} & & \text{(in dB}\mu\text{V)} & & \text{(in dB)}
 \end{array}$$

Typical antenna correction factors for the ALT-930-2M are given in Table 4 and Figure 21.

Table 4 - Typical Antenna Correction factors Table

Antenna Type:		Triple Loop Antenna					
Model:		ALT-930-2M					
Serial Number:		XXXXXXXX					
Calibration Date:		mm/dd/yy					
Frequency (MHz)	Validation Measurement Values					CISPR 16-1-4 Validation Factor (dBΩ)	Antenna Correction Factor (dB)
	X-axis (dBΩ)	Y-axis (dBΩ)	Z-axis (dBΩ)	Maximum Deviation from Average (dB)	Average of X/Y/Z Values (dBΩ)		
0.009	82.77	83.2	83.1	0.25	83.02	74.0	9.02
0.01	82.0	82.15	81.85	0.15	82.0	74.0	8.0
0.03	72.85	72.67	72.77	0.09	72.76	73.8	-1.04
0.05	68.1	67.9	68.17	0.16	68.06	73.8	-5.74
0.1	61.99	62.17	62.1	0.1	62.09	73.8	-11.71
0.3	53.6	53.2	53.27	0.24	53.36	73.9	-20.54
0.5	50.98	50.95	51.0	0.03	50.98	74.0	-23.02
1	49.49	49.51	49.44	0.04	49.48	74.3	-24.82
3	50.9	51.3	51.15	0.22	51.12	76.2	-25.08
5	53.69	53.7	53.67	0.02	53.69	78.7	-25.01
10	59.03	58.9	58.7	0.18	58.88	83.5	-24.62
15	62.25	61.96	62.3	0.21	62.17	86.5	-24.33
20	64.73	64.84	64.7	0.08	64.76	88.3	-23.54
25	66.81	66.75	66.79	0.03	66.78	89.7	-22.92
30	69.25	69.1	69.17	0.08	69.17	91.2	-22.03

Calibration performed per: CISPR 16-1-4

Radiated Disturbance Level (dBμA) = Meter Reading (dBμV) + Antenna Correction Factor (dB)

Typical Antenna Correction Factors
ALT-930-2M Triple Loop Antenna

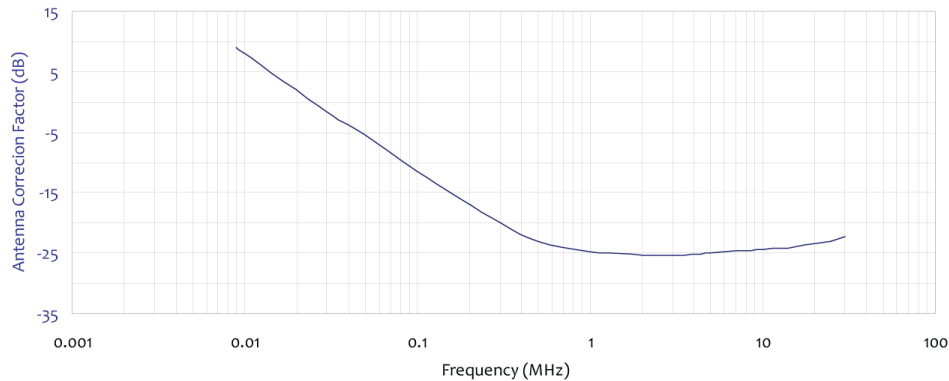
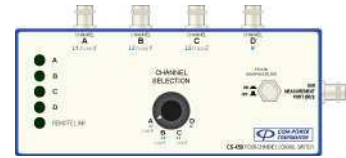

Figure 21 - Typical Antenna Correction Factors Graph

SECTION 6 - USING THE ALT-930-2M TRIPLE LOOP ANTENNA

6.2 Operation of CS-450 Coaxial Switch

The CS-450 Four-Channel Coaxial Switch is installed between the three loop/current to voltage transducer assemblies and the measuring instrument. The Channel A, B and C inputs connect to the X, Y and Z axis loop assemblies, respectively. The output of the coaxial switch connects to the measuring instrument. The Channel D input is not used with the ALT-930-2M Triple Loop Antenna.



The switch is used to select which loop assembly is connected to the measuring instrument, and to internally terminate the other two loop assemblies into fifty ohms.

The CS-450 may be operated locally using its mechanical selection knob, as described in section 6.2.1; or, it can also be operated remotely using the optional RLI-100 Remote Interface, as described in section 6.2.2.

IMPORTANT NOTE: THE 150 kHz HIGH-PASS FILTER IS NOT INTENDED TO BE USED IN CONJUNCTION WITH THE ALT-930-2M TRIPLE LOOP ANTENNA, AND SHOULD REMAIN IN THE OFF POSITION. IN THE ON POSITION, THE FILTER WILL ATTENUATE ANY SIGNALS PRESENT BETWEEN 9 kHz AND 150 kHz, RENDERING ANY MEASUREMENTS WITHIN THAT BAND INVALID.

6.2.1 Local Operation of CS-450 Coaxial Switch

When operated locally, the mechanical selection knob on the CS-450 coaxial switch is used to select which loop assembly is connected to the measuring instrument. It is not necessary to power the CS-450 when used locally.

In this mode, the white arrow indicator on the selection knob indicates which input channel is selected. The LED indicators will not illuminate unless the CS-450 is operated remotely (see section 6.2.2).

Illustrated in Figure 22 is a typical setup for local operation of the CS-450 switch.

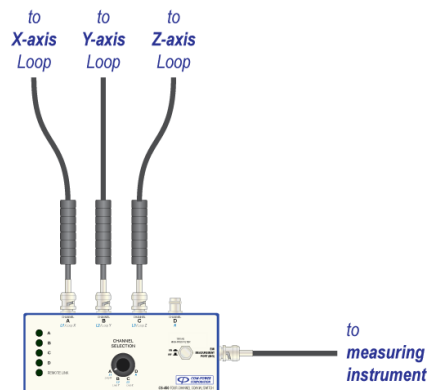

Figure 22 - Typical Setup for Local Operation using CS-450 Coaxial Switch

6.2.2 Remote Operation of CS-450 Coaxial Switch using RLI-100 Remote Interface

The optional RLI-100 Remote Interface connects directly to the CS-450 Coaxial Switch via fiber optic interface as illustrated in Figure 23.

Both the RLI-100 and CS-450 must be powered using the supplied AC Adapters. Once connected via the fiber optic cable, the two powered devices will automatically negotiate a connection, at which point the Remote Link LED indicator on the CS-450, along with the default Channel A input LED indicators on both the RLI-100 and CS-450, will illuminate.

When the remote link is active, only the RLI-100 controls will be operational, as the CS-450 selection knob is bypassed.

On the RLI-100, the L1, L2 and L3 buttons are used to operate the CS-450 coaxial switch as shown in Table 5.

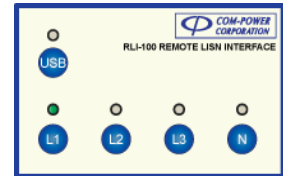

Table 5 – Cross-reference Table of RLI-100 Buttons vs CS-450 Input Channels

RLI-100 Button	CS-450 Input Channel
L1	Channel A – X-axis Loop
L2	Channel B – Y-axis Loop
L3	Channel C – Z-axis Loop
N	Channel D – not used

Located directly above each of the RLI-100 buttons is an LED indicator. The LED corresponding to the currently selected channel will be illuminated.

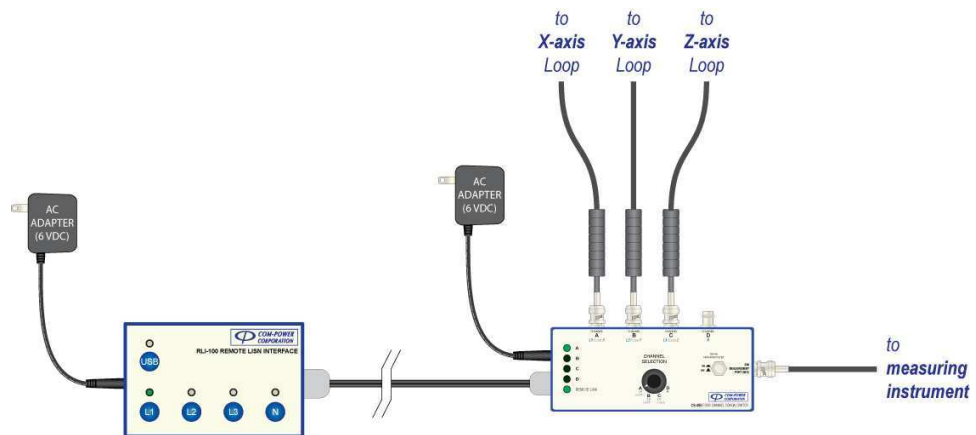

Figure 23 - Setup for Remote Operation of CS-450 Switch via RLI-100 Remote Interface

SECTION 6 - USING THE ALT-930-2M TRIPLE LOOP ANTENNA

6.3 Radiated Electromagnetic Disturbance Measurements

The ALT-930-2M can be used to perform tests on devices not exceeding an overall length of 1.6 meters. The Equipment Under Test (EUT) should be mounted on a non-conductive stand so that it is located in the approximate center of the loop structure. The exact position is not critical. Depending on the size and weight of the EUT, the mounting structure for the balun-dipole (if purchased) can be used to support the EUT by removing the Vertical Post Clamp from the Horizontal Support Piece. This is accomplished by removing the screw(s) from the under side of the Horizontal Support Piece.

As per the CISPR 15 standard, the fields are measured successively in three orthogonal axis (X, Y, Z). The CS-450 Four-Channel Coaxial Switch is used to switch between the loops. Each of the three loops is terminated into 50 ohms. The loop selected by the switch is terminated by the input impedance of the measuring instrument, while the other two loops are terminated internal to the switch.

To avoid unwanted capacitive coupling between the EUT and the ALT-930-2M Triple Loop Antenna, the distance between the EUT and components of the antenna should be at least 20 cm. Any EUT cables should be routed together and leave the loop volume in the same octant of the cell, no closer than 40 cm to any of the loops.

A typical test setup is illustrated in Figure 24.

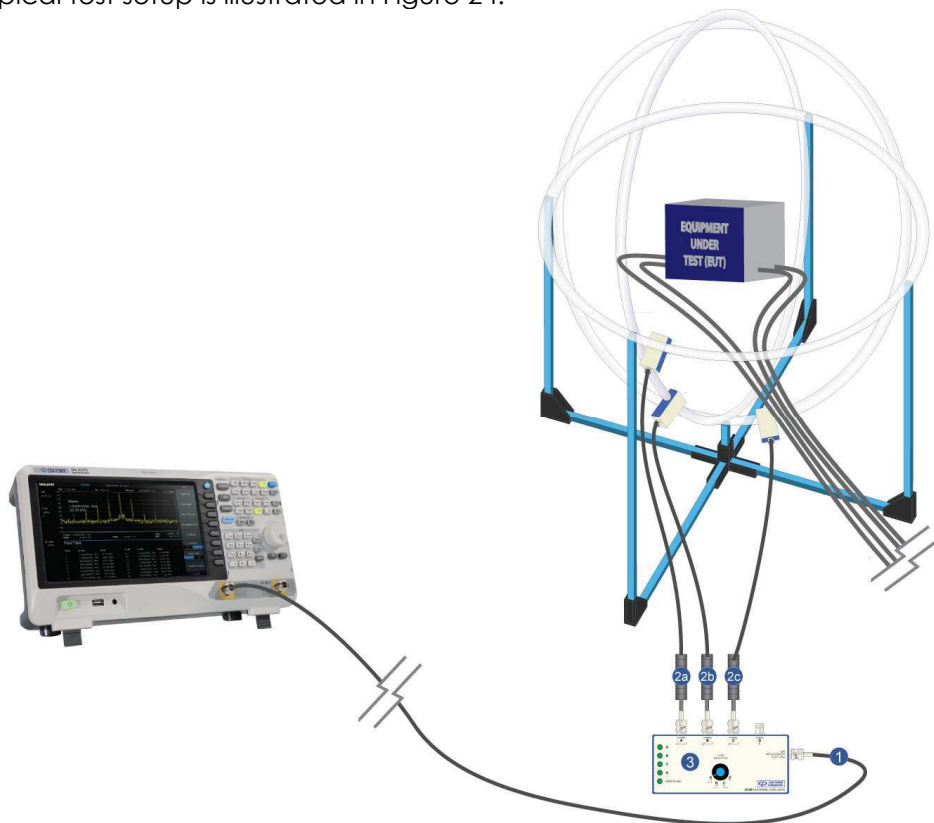

Figure 24 - Typical Test Setup for Disturbance Measurements

SECTION 6 - USING THE ALT-930-2M TRIPLE LOOP ANTENNA

The voltage values (in dBμV) measured for each loop axis by the measuring instrument having an input impedance of 50 ohms are converted to current (in dBμA) using Equation 1. These converted current values can then be compared directly against the appropriate specification limit. The CISPR 15 (EN 55015) limit for a typical device is given in Figure 25, along with typical corrected floor noise data.

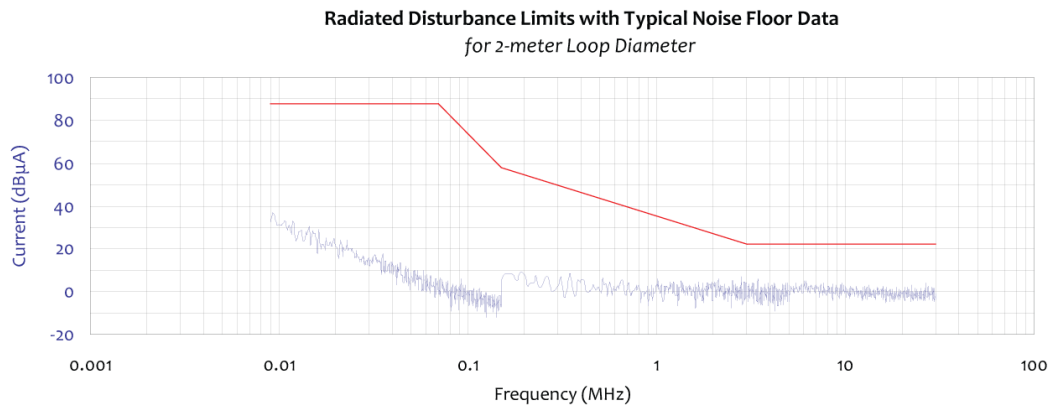

Figure 25 – CISPR 15/EN 55015 Radiated Disturbance Limits for 2-meter Loop

EXAMPLE CALCULATION #1:

A signal at **10 MHz** has a measured value of **40 dBμV** on a measurement instrument having a nominal input impedance of 50Ω.

As per Table 4, -24.62 dBΩ is the antenna correction factor at 10 MHz; therefore, the radiated disturbance level is calculated using Equation 1:

$$40.0 \text{ dB}\mu\text{V} + -24.62 \text{ dB} = 15.38 \text{ dB}\mu\text{A}$$

The radiated disturbance level, or loop current induced by the signal is **15.38 dBμA**, which is 6.62 dB under the CISPR 15 (EN 55015) specification limit of 22 dBμA.

6.3.1 Interpolation of Antenna Correction factors

In order to find the antenna correction factor for frequencies between those listed in the table, Equation 2 may be used for interpolation:

Equation 2 – Interpolation of Factors

$$ACF_x = ACF_1 + (ACF_2 - ACF_1) \left(\frac{\log(f_x/f_1)}{\log(f_2/f_1)} \right)$$

where:

ACF_x = unknown antenna conversion factor at f_x

ACF_1 = antenna correction factor at f_1

ACF_2 = antenna correction factor at f_2

f_x = frequency at which antenna conversion factor is desired

f_1 = frequency just below f_x

f_2 = frequency just above f_x

EXAMPLE CALCULATION #2:

In this example, the antenna correction factor at **12 MHz** is calculated. Using the Table 4, the following values are known:

Frequency		Antenna Conversion Factor (50Ω)	
f_1	10 MHz	ACF_1	-24.62 dBΩ
f_2	15 MHz	ACF_2	-24.03 dBΩ

Using Equation 2, the antenna correction factor at 12 MHz is calculated as ACF_x :

$$ACF_x = -24.62 + (-24.03 - -24.62) \left(\frac{\log(12/10)}{\log(15/10)} \right) \text{ dB}\Omega$$

$$ACF_x = \mathbf{-24.35 \text{ dB}\Omega}$$

7.0 Calibration

Your ALT-930-2M Loop Antenna has been individually calibrated with NIST traceability, and the appropriate data and certificate has been provided. Periodic re-calibration is recommended. Calibration intervals is left to your discretion, but should be chosen based on the frequency with which the antenna is used, and/or as allowed for by your internal quality control system (if applicable). Com-Power offers NIST traceable calibration services. Recognized ISO 17025 accredited calibrations are also available.

The following sections describe the basic process for determining/verifying the antenna's compliance with the CISPR 16-1-4 standard, as well as determining/verifying the antenna correction factors over its frequency range of 9 kHz to 30 MHz.

7.1 Calibration Equipment

The following sections detail the equipment needed for performing calibration of the ALT-930-2M Triple Loop Antenna.

7.1.1 Source Equipment

Any stable signal source, or combination of signal sources, having an output impedance of 50 ohms, and which operates over the frequency range of 9 kHz to 30 MHz with sufficient amplitude may be used for the calibration. Listed below are some examples of signal sources:

- *Synthesized signal generator*
- *Function generator*
- *Network analyzer*
- *Spectrum analyzer with tracking generator*

7.1.2 Measuring Instruments

Two types of measuring instruments are needed for the calibration.

For the measurement of the open circuit voltage of the generator, a high input impedance is needed, such as an oscilloscope with a 1 M Ω input.

For the measurement of the ALT-930-2M output, an input impedance of 50 ohms is required, such as a spectrum analyzer, EMI receiver or Network Analyzer.

Each instrument should be calibrated and be capable of measurements over the frequency range of 9 kHz to 30 MHz.

7.1.3 Balun-Dipole as Transmitting Antenna

A balun-dipole antenna, as described in Annex C of CISPR 16-1-4 must be used. The Com-Power Balun-Dipole antenna, which is included as a component in the ALT-930-CKIT Calibration Kit, is the recommended transmitting antenna to use for the calibration.

SECTION 7 - CALIBRATION

7.2 Calibration Parameters

7.2.1 Required Measurements

The calibration is performed according to Annex A of CISPR 16-1-4. Calibration is performed on each of the three (3) loops, each with the Balun-Dipole transmitting antenna oriented in eight (8) different positions, for a total of 24 sets of measurements to be performed over the frequency range of 9 kHz to 30 MHz. The eight (8) positions are illustrated in Figure 26. The Balun-Dipole mounting block is 'keyed' to the Balun-Dipole, so that it can be mounted into the exact prescribed positions, as shown in Figure 27.

A single "set" of measurements, for the purposes of this document, is one group of measurements in a given antenna position over the complete frequency range of the calibration.

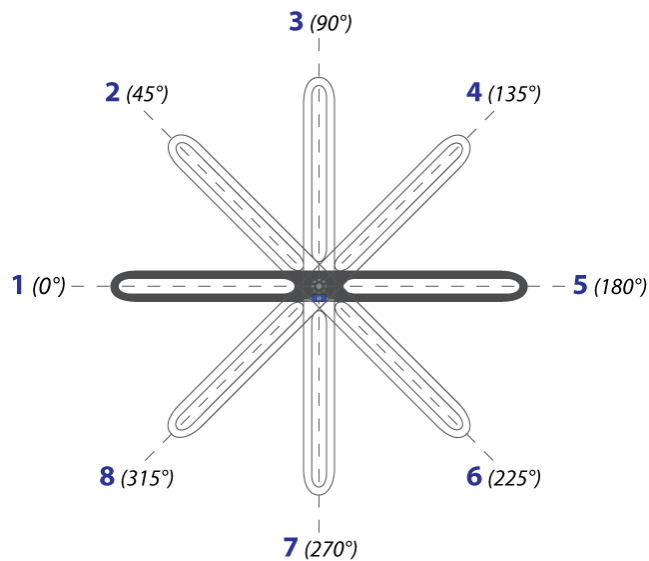

Figure 26 - Balun-Dipole Positions During Calibration

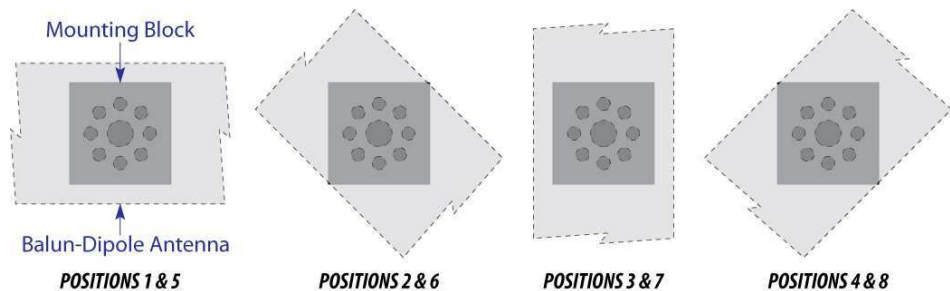

Figure 27 - 'Keyed' Mounting of Balun-Dipole onto Mounting Block

SECTION 7 - CALIBRATION

For the purposes of this document, the 24 sets of measurements are referred to as shown in Table 6 below:

Table 6 - Required Calibration Measurements Table

Position # - Angle	Data Sets for X-axis Loop	Data Sets for Y-axis LOOP	Data Sets for Z-axis LOOP
Position 1 - 0°	X1	Y1	Z1
Position 2 - 45°	X2	Y2	Z2
Position 3 - 90°	X3	Y3	Z3
Position 4 - 135°	X4	Y4	Z4
Position 5 - 180°	X5	Y5	Z5
Position 6 - 225°	X6	Y6	Z6
Position 7 - 270°	X7	Y7	Z7
Position 8 - 315°	X8	Y8	Z8

7.2.2

Calibration Frequencies

The frequency resolution (number of frequency points across the frequency range of the antenna) with which the antenna is calibrated is left to the discretion of the user. However, it has been shown that calibration performed at the frequencies shown in the Table 7 accurately demonstrates the actual frequency response curve of the antenna. .

Table 7 - Recommended Calibration Frequencies

RECOMMENDED CALIBRATION FREQUENCIES IN MHz		
0.009	0.3	10
0.01	0.5	15
0.03	1	20
0.05	3	25
0.1	5	30

The calibration frequencies given in Table 7 - Recommended Calibration Frequencies

represent the minimum recommended number of calibration frequencies. Calibrations performed at a lesser number of frequencies, and/or at different frequency points than shown in the table, may not accurately demonstrate the frequency response of the antenna.

SECTION 7 - CALIBRATION

7.2.3 Amplitude of the Signal Source Output

In order to maximize signal to noise ratio, the amplitude setting of the signal source should be set to the maximum possible without becoming unstable.

Most synthesized signal generators are capable of producing an output level of 1 V_{rms}, which is equal to 120 dB μ V, or 13 dBm. Some sources are only capable of 0.5 V_{rms} (114 dB μ V, or 7 dBm). Anything less than the latter may result in a signal to noise ratio which is insufficient for obtaining accurate measurements during the calibration process.

Choose the highest setting available which does not cause a "REF UNLOCK" or similar error to occur on the generator.

The signal source output level should remain constant throughout the calibration process.

7.3 Calibration Process

The first part of the calibration process is the reference measurements, according to the procedure contained in Section 7.3.1. The second part of the calibration includes the 24 sets of calibration measurements discussed in Section 7.2.1, according to the procedure contained in Section 7.3.2.

Both the reference measurements and each set of calibration measurements must be performed at each calibration frequency (see section 7.2.2).

As there are multiple calculations that will need to be performed on the measurement results data, it is recommended that all results be recorded into a spreadsheet, such as a Microsoft Excel workbook.

7.3.1 Reference Measurements

The reference measurements are performed in order to quantify and record the open-circuit voltage level that will be applied to the input terminals of the balun-dipole antenna over the frequency range of the calibration. Only one set of reference measurements need be performed, as the single set of reference measurements will be referenced for each of the 24 sets of calibration measurements.

Illustrated in Figure 28 is the equipment setup for the reference measurements.

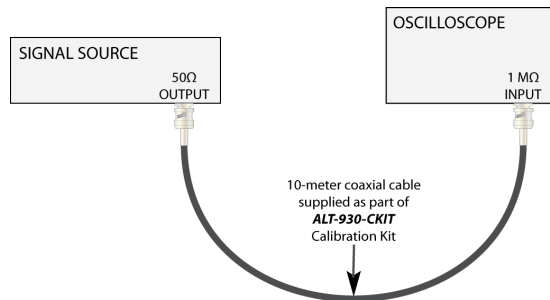

Figure 28 - Equipment Setup for Reference Level Measurements

The signal source as well as the signal source amplitude setting (see section 7.2.3) used during the reference measurements must be the same as those used during the calibration measurements described in Section 7.3.2. In addition, the cable used to connect the signal source to the oscilloscope must be the same cable which will be used to connect the signal source to the Balun-Dipole during the calibration measurements.

NOTE: The measured open circuit voltage of a 50 ohm signal source will, in linear terms, be twice that which is set/indicated on the signal generator; or, in logarithmic terms, 6 dB higher than that which is set/indicated.

Step #1 Tune the signal source and measuring instrument to 9 kHz CW. The signal source amplitude setting should be set to the same level as that which will be used for the calibration measurements. Refer to section 7.2.3.

Step #2 Using the oscilloscope, measure the open-circuit RMS voltage.

Step #3 Record the measured open-circuit RMS voltage value indicated on the oscilloscope (in Volts). Then, convert this voltage into logarithmic units with reference to 1 μV (dBμV).

Equation 3 – Conversion of Linear Voltage to Logarithmic

$$[dB\mu V] = 20 * \log([V_{rms}] * 1,000,000)$$

Step #4 Tune the signal source to the next calibration frequency, and repeat steps 2 through 4 until measurements at all calibration frequencies have been measured and recorded.

SECTION 7 - CALIBRATION

7.3.2 Calibration Measurements

For all calibration measurements, the balun-dipole is mounted with the plane of its loop coincident with the plane of the loop being calibrated.

Figure 29 illustrates this arrangement for calibration of the X-axis loop.

Figure 30 illustrates this arrangement for calibration of the Y-axis and Z-axis loops.

Step #1 Configure the calibration setup as shown in Figure 29 for X-axis loop calibration, with the Balun-Dipole in position 1. Set the coaxial switch to the position corresponding to the X-axis loop.

OVERHEAD VIEW

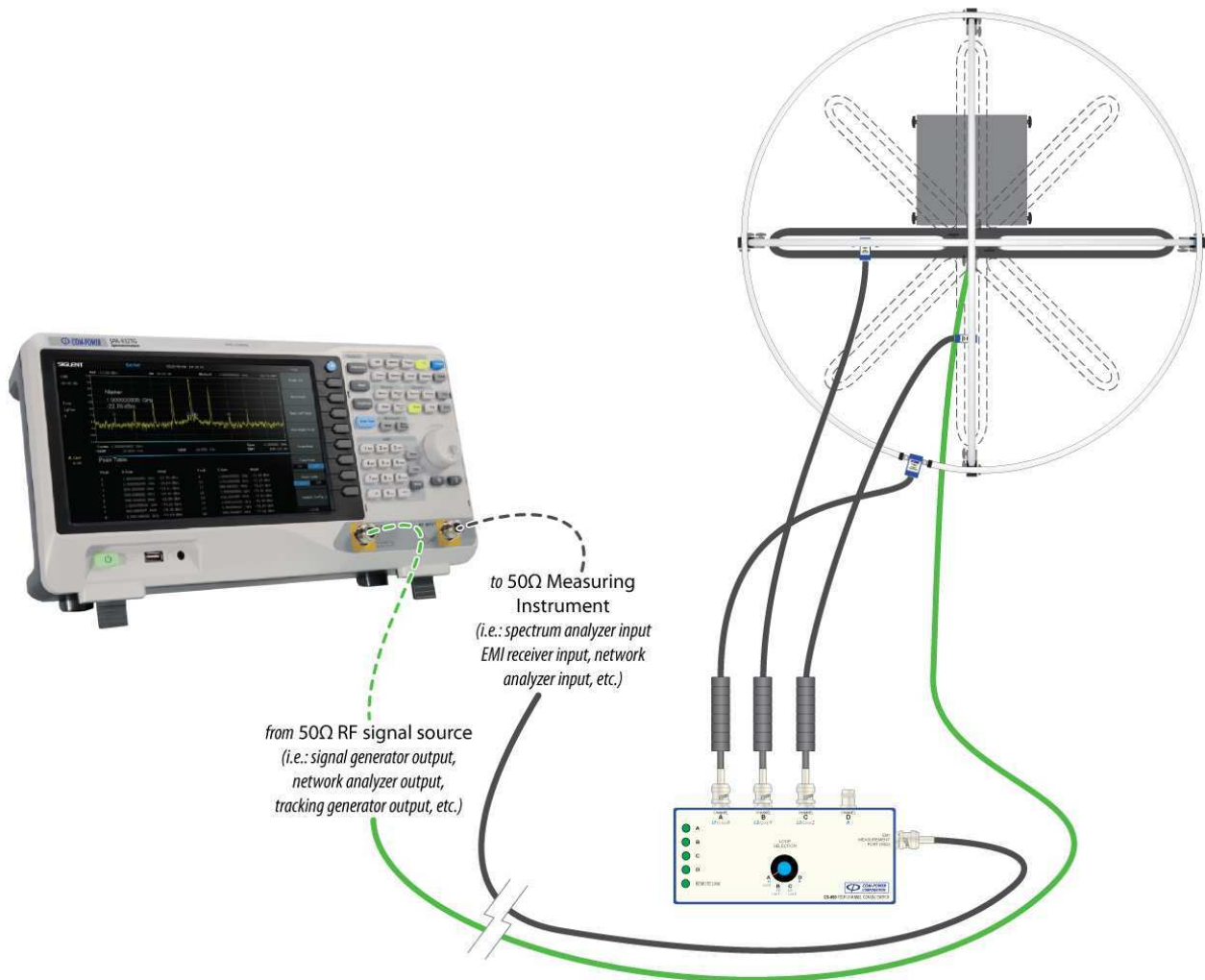

Figure 29 - Measurement Arrangement for X-axis Calibration

SECTION 7 - CALIBRATION

- Step #2** Tune the signal source and measuring instrument to 9 kHz. The signal source amplitude setting should be set to the same level as that used for the reference measurements.
- Step #3** Measure and record the rms voltage level (in dBμV) indicated on the measuring instrument
- Step #4** Tune the signal source to the next calibration frequency, and repeat steps 3 through 4 until measurements have been recorded for each of the test frequencies.
- Step #5** Orient the Balun-Dipole for the next position and repeat steps 2 through 5 until measurements have been recorded at all calibration frequencies for each of the eight (8) Balun-Dipole positions.
- Step #6** Configure the calibration setup as shown in Figure 30 for Y-axis loop calibration, with the Balun-Dipole in position 1. Set the coaxial switch to the position corresponding to the Y-axis loop.

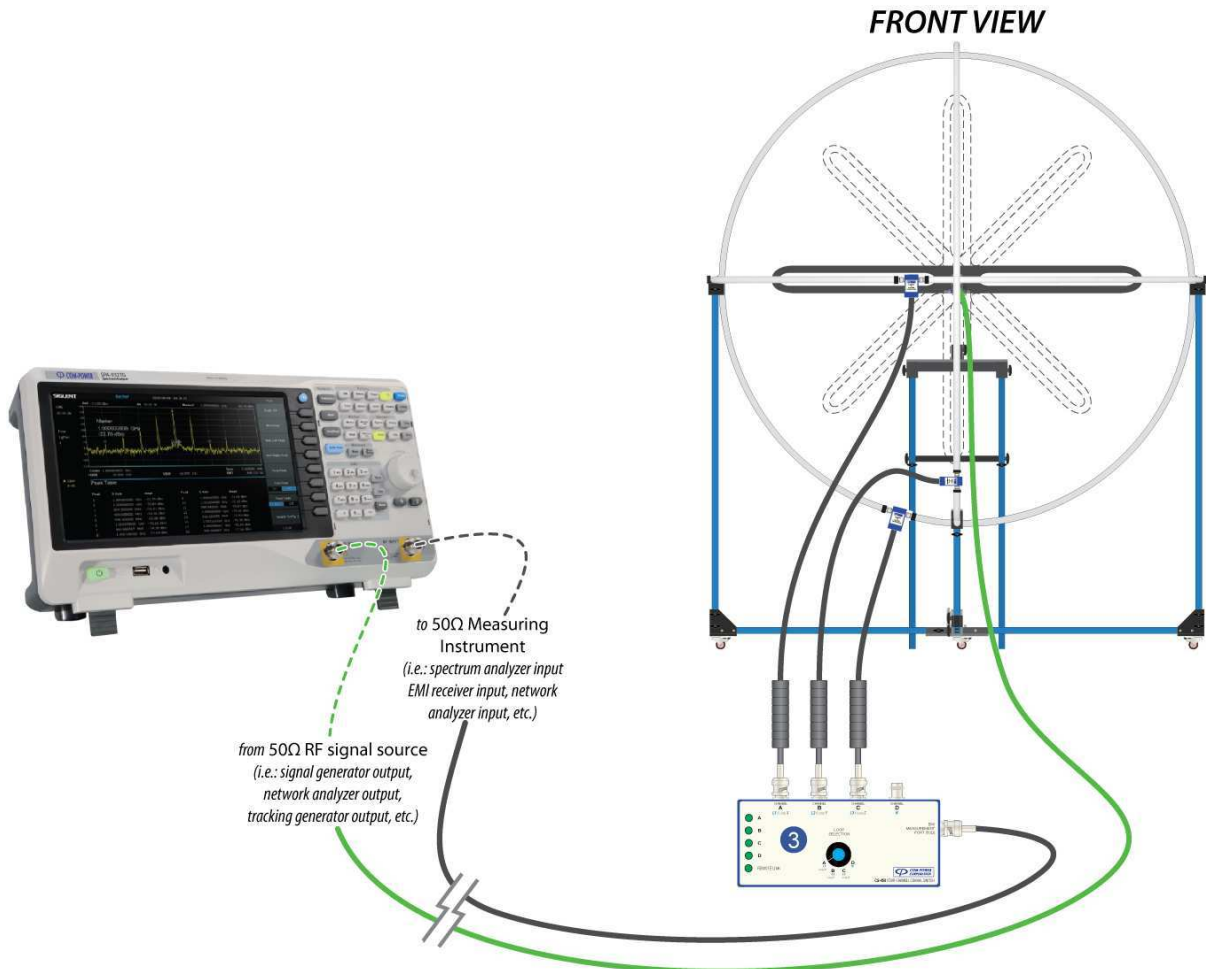

Figure 30 - Measurement Arrangement for Y/Z-axis Calibration

SECTION 7 - CALIBRATION

Repeat steps 2 through 5 until all until measurements have been recorded for all calibration frequencies at each of the eight (8) Balun-Dipole positions for the Y-axis loop.

Step #7

Configure the calibration setup as shown in Figure 30 for Z-axis loop calibration, with the Balun-Dipole in position 1. Set the coaxial switch to the position corresponding to the Z-axis loop.

Repeat steps 2 through 5 until all until measurements have been recorded for all calibration frequencies at each of the eight (8) Balun-Dipole positions for the Z-axis loop.

Step #8

Calculate the average of the eight (8) measured values for the eight Balun-Dipole positions at each measurement frequency for the X-axis, Y-axis and Z-axis, respectively using Equation 4.

Equation 4 – Calculating the average of X1...X8, Y1...Y8 & Z1...Z8

$$\begin{aligned}
 \text{XA} &= \frac{X1 + X2 + X3 + X4 + X5 + X6 + X7 + X8}{8} \\
 \text{YA} &= \frac{Y1 + Y2 + Y3 + Y4 + Y5 + Y6 + Y7 + Y8}{8} \\
 \text{ZA} &= \frac{Z1 + Z2 + Z3 + Z4 + Z5 + Z6 + Z7 + Z8}{8}
 \end{aligned}$$

Label the averaged values “XA”, “YA” and “ZA”. The number of values for each label should be equal to the number of measurement frequencies (i.e.: if there are 15 total measurement frequencies, then you should have 15 “XA” values, 15 “YA” values and 15 “ZA” values, for a total of 45 values.). Table 8 is given as an example (showing only X-axis loop data).

Table 8 - Example Calibration Results Table #1

Calibration Frequency (MHz)	Signal Source Amplitude Setting (dBμV)	Reference Measurements (REF) (Volts) (dBμV)		X-axis LOOP								
				X1 (0°) (dBμV)	X2 (45°) (dBμV)	X3 (90°) (dBμV)	X4 (135°) (dBμV)	X5 (180°) (dBμV)	X6 (225°) (dBμV)	X7 (270°) (dBμV)	X8 (315°) (dBμV)	XA = average (X1...X8) (dBμV)
0.009	114	1	120	37	37.17	37.17	37	37.17	37.33	37	38	37.23
↓	↓	↓	↓	↓	↓	↓	↓	↓	↓	↓	↓	↓
30	114	1	120	49.61	49.77	50.94	52.44	52.4	50.77	50.04	50.04	50.75

At each frequency, the measured values (X1...X8, Y1...Y8, Z1...Z8) must all be within ±2 dB of their respective averaged value (XA/YA/ZA).

For example, in the following table, the “min. limit” and “max. limit” values are equal to “XA” ±2 dB, respectively. Each of the “X1” through “X8” values in a given row must be within the limits for that row. Table 9 is given as an example (showing only X-axis loop data).

SECTION 7 - CALIBRATION

Table 9 - Example Calibration Results Table #2

Calibration Frequency (MHz)	Signal Source Amplitude Setting (dBμV)	Reference Measurements (REF) (Volts) (dBμV)		X-axis LOOP								XA = average (X1...X8) (dBμV)	min. limit (dBμV)	max limit (dBμV)
				X1 (0°) (dBμV)	X2 (45°) (dBμV)	X3 (90°) (dBμV)	X4 (135°) (dBμV)	X5 (180°) (dBμV)	X6 (225°) (dBμV)	X7 (270°) (dBμV)	X8 (315°) (dBμV)			
0.009	114	1	120	37	37.17	37.17	37	37.17	37.33	37	38	37.23	35.23	39.23
↓	↓	↓	↓	↓	↓	↓	↓	↓	↓	↓	↓	↓	↓	↓
30	114	1	120	49.61	49.77	50.94	52.44	52.4	50.77	50.04	50.04	50.75	48.75	52.75

Step #9. Subtract the XA/YA/ZA values for each frequency (calculated in Step #8) from the respective reference measurement values using Equation 5. Label these values as XC/YC/ZC. There should be the same number of XC/YC/ZC values as there are XA/YA/ZA values.

Equation 5 – Correction of XA/YA/ZA Values

$$\begin{aligned}
 \text{XC (in dB}\Omega\text{)} &= \text{Reference Measurement (in dB}\mu\text{V)} - \text{XA (in dB}\mu\text{V)} \\
 \text{YC (in dB}\Omega\text{)} &= \text{Reference Measurement (in dB}\mu\text{V)} - \text{YA (in dB}\mu\text{V)} \\
 \text{ZC (in dB}\Omega\text{)} &= \text{Reference Measurement (in dB}\mu\text{V)} - \text{ZA (in dB}\mu\text{V)}
 \end{aligned}$$

An example is given in Table 10 (showing only X-axis loop data).

Table 10 - Example Calibration Results Table #3

Calibration Frequency (MHz)	Signal Source Amplitude Setting (dBμV)	Reference Measurements (REF) (Volts) (dBμV)		X-axis LOOP								XA = average (X1...X8) (dBμV)	min. limit (dBμV)	max limit (dBμV)	XC = (REF) - (XA) (dBΩ)
				X1 (0°) (dBμV)	X2 (45°) (dBμV)	X3 (90°) (dBμV)	X4 (135°) (dBμV)	X5 (180°) (dBμV)	X6 (225°) (dBμV)	X7 (270°) (dBμV)	X8 (315°) (dBμV)				
0.009	114	1	120	37	37.17	37.17	37	37.17	37.33	37	38	37.23	35.23	39.23	82.77
↓	↓	↓	↓	↓	↓	↓	↓	↓	↓	↓	↓	↓	↓	↓	↓
30	114	1	120	49.61	49.77	50.94	52.44	52.4	50.77	50.04	50.04	50.75	48.75	52.75	69.25

SECTION 7 - CALIBRATION

FINAL CALCULATIONS:

The remaining steps of this procedure describe the calculations for the example in Table 11, which is the same format as that shown in Table 4:

Table 11 - Example Calibration Results Table #4

Frequency (MHz)	Validation Measurement Values					Validation Factor (CISPR 16-1-4) (dBΩ)	Antenna Correction Factor (XYZF) (dB)
	X-axis (XC) (dBΩ)	Y-axis (YC) (dBΩ)	Z-axis (ZC) (dBΩ)	Maximum Deviation from Average (ΔXYZ) (dB)	Average (XYZA) (dBΩ)		
	0.009	82.77	83.2	83.1	0.25		
↓	↓	↓	↓	↓	↓	↓	↓
30	69.25	69.1	69.17	0.08	69.17	91.2	-22.03

Step #10 Calculate the average of the “XC”, “YC” and “ZC” values for each respective calibration frequency using Equation 6.

Equation 6 – Calculating the Average of XC, YC & ZC

$$XYZA = \frac{XC + YC + ZC}{3}$$

Record these values as “XYZA” for each calibration frequency.

Step #11 Calculate the maximum deviation between the “XYZA” values and the respective “XC”/”YC”/”ZC” values at each frequency as shown in Equation 7.

Equation 7 – Calculation of ΔXYZ

$$\Delta XYZ = \max(|XYZA - XC|, |XYZA - YC|, |XYZA - ZC|)$$

Record these values as “ΔXYZ” for each calibration frequency.

The calculated “ΔXYZ” values must be equal to or less than 2 dB.

SECTION 7 - CALIBRATION

Step #12

Determine and record the Validation Factor for each calibration frequency using the graph shown in Figure 31, or from Table 4 for those calibration frequencies given in Table 7 - Recommended Calibration Frequencies

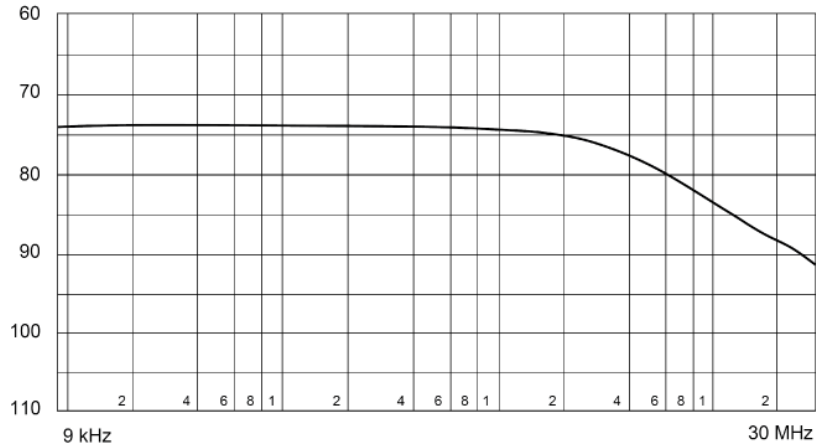

Figure 31 - Validation Factor Graph from CISPR 16-1-4

Step #13

Lastly, using Equation 8, calculate the antenna correction factor for each calibration frequency by subtracting the Validation Factor at each calibration frequency from the respective "XYZA" value.

Equation 8 – Calculation of Antenna Correction factor

$$\text{Antenna Correction Factor (XYZF)} = \text{XYZA} - \text{CISPR 16-1-4 Validation Factor}$$

SECTION 7 - CALIBRATION

8.0 Warranty

Com-Power warrants to its Customers that the products it manufactures will be free from defects in materials and workmanship for a period of three (3) years. This warranty shall not apply to:

- Transport damages during shipment from your plant.
- Damages due to poor packaging.
- Products operated outside their specifications.
- Products Improperly maintained or modified.
- Consumable items such as fuses, power cords, cables, etc.
- Normal wear
- Calibration
- Products shipped outside the United States without the prior knowledge of Com-Power.

In addition, Com-Power shall not be obliged to provide service under this warranty to repair damage resulting from attempts to install, repair, service or modify the instrument by personnel other than Com-Power service representatives.

Under no circumstances does Com-Power recognize or assume liability for any loss, damage or expense arising, either directly or indirectly, from the use or handling of this product, or any inability to use this product separately or in combination with any other equipment.

When requesting warranty services, it is recommended that the original packaging material be used for shipping. Damage due to improper packaging will void warranty.

In the case of repair or complaint, Please visit our website www.com-power.com and fill out the service request form (<http://com-power.com/repairservicereq.asp>). Our technical assistance personnel will contact you with an RMA number. The RMA number should be displayed in a prominent location on the packaging and on the product, along with a description of the problem, and your contact information.

SECTION 8 - WARRANTY

9.0 Maintenance

This product contains no user serviceable parts. If the unit does not operate or needs calibration, please contact Com-Power Corporation. Any modifications or repairs performed on the unit by someone other than an authorized factory trained technician will void warranty.

The exterior surface may be cleaned with mild detergent and then be wiped with a dry, clean, lint-free cloth. Use care to avoid liquids or other foreign objects entering the chassis.